



FR-A LIRE AVEC ATTENTION ET A CONSERVER POUR CONSULTATION ULTERIEURE.
 GB•PLEASE READ THESE INSTRUCTIONS CAREFULLY AND KEEP THIS DOCUMENT FOR FUTURE REFERENCE / IT•DA LEGGERE CON ATTENZIONE E CONSERVARE PER ULTERIORE CONSULTAZIONE / DE•BITTE LESEN SIE DIESE ANLEITUNG AUFMERKSAM DURCH UND BEWAHREN SIE SORGFÄLTIG AUF / DK•LÆS VENLIGST DISSE INSTRUKTIONER OG GEM DETTE DOKUMENT ES•LEER CON ATENCIÓN Y CONSERVAR PARA CONSULTAS POSTERIORES / PT•P.F. LEIA ATENTAMENTE E CONSERVE PARA CONSULTA POSTERIOR / CZ•ČTĚTE PROSÍM TYTO POKYNY POZORNĚ A UCHOVĚJTE TENTO DOKUMENT PRO BUDOUCÍ POTŘEBU / SE•LÄS DENNA HANDLEDNING NOGRANT OCH SPARA DEN FÖR FRAMTIDA BRUK / NL•A.U.B. LEES DEZE INSTRUCTIES ZORGVULDIG EN HOU ZE BIJ VOOR VERDERE CONSULTATIES GR•ΜΑΒΑΣΤΕ ΠΡΟΣΕΚΤΙΚΑ ΤΙΣ ΟΔΗΓΙΕΣ ΠΟΥ ΑΚΟΛΟΥΘΟΥΝ ΚΑΙ ΚΡΑΤΗΣΤΕ ΤΟ ΠΑΡΟΝ ΕΓΧΡΩΣΤΟ ΓΙΑ ΜΕΛΛΟΝΤΙΚΗ ΧΡΗΣΗ

FR . En fonction des conditions d'utilisation, et de la sollicitation du produit vérifier régulièrement le serrage des éléments de liaison (vis, écrou...).

GB . Depending on conditions and frequency of use of the product, regularly check the tightness of connecting elements (screws, nuts ...).

DE . Je nach Benutzung, regelmässig prüfen, dass die Verbindungselemente festgeschraubt sind (Schrauben, Muttern, ...).

FR . Charge maximale des étagères: 35 kg. Rigueur d'utilisation Niveau 1 (Ecoles primaires, crèches, bureaux, bibliothèques, maison de retraite).

GB . Maximum weight per shelf: 15 kg. Level 1 proper use: (Primary schools, kindergartens, offices, libraries, retirement homes).

DE . Höchstgewicht pro Regal: 15 kg. Level 1, für die korrekte Verwendung in Grundschulen , Kindergärten , Büros, Bibliotheken, Seniorenheime .



Ref. **49 8,79**

Ref. **45 7,55**

- 1A (70706)
- 1B (70707)
- 1C (70708)
- 1D (68089)
- 1E (48211)



 (Option)

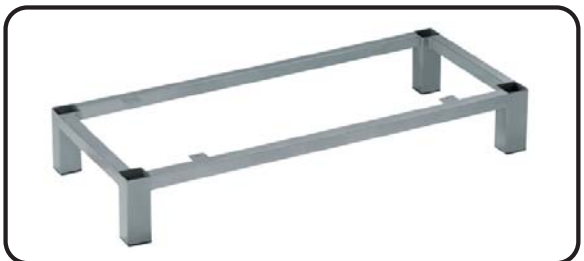

Ref. **22 258**



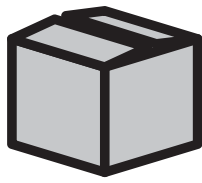

COMPOSITION

Zusammenstezung

A (70706) (MP1321)

2 (MP1483)

2' (MP1482)

B (70707)

4 x2 (MP49154)

8 (MP1470)

MP9459 x2

C (70708)

1 (MP2050)

1' (MP49133)

3 (MP2051)

(SF1023)

q x2 (MP1216)

r x2 (MP263)

s x2 (MP1217)

(SF49042)

a x8 (MP9345)

b x8 (MP9324)

c x8 (MP9311)

f x5 (MP9334)

g x5 (MP854)

j x1 (MPxxxx) 35 KG MAX

y x4 (MP303001)

z x4 (MP7161000)

D (68089)

7 (MP49007)

(SF183)

d x10 (MP9408)

p x1 (MP9316)

j x1 (MPxxxx) 35 KG MAX

E (48211)

6 (MP6221)

6' (MP6222)

(SF1066)

h x4 (MP9331)

k x18 (MP9348)

i x6 (MP578)

l x1 (MP433)

o x1 (MP2044)

j x6 (MP9317)

n x2 (MP6287)

(Option)

Ref. - - - -22 258

e x4 (MP9409)

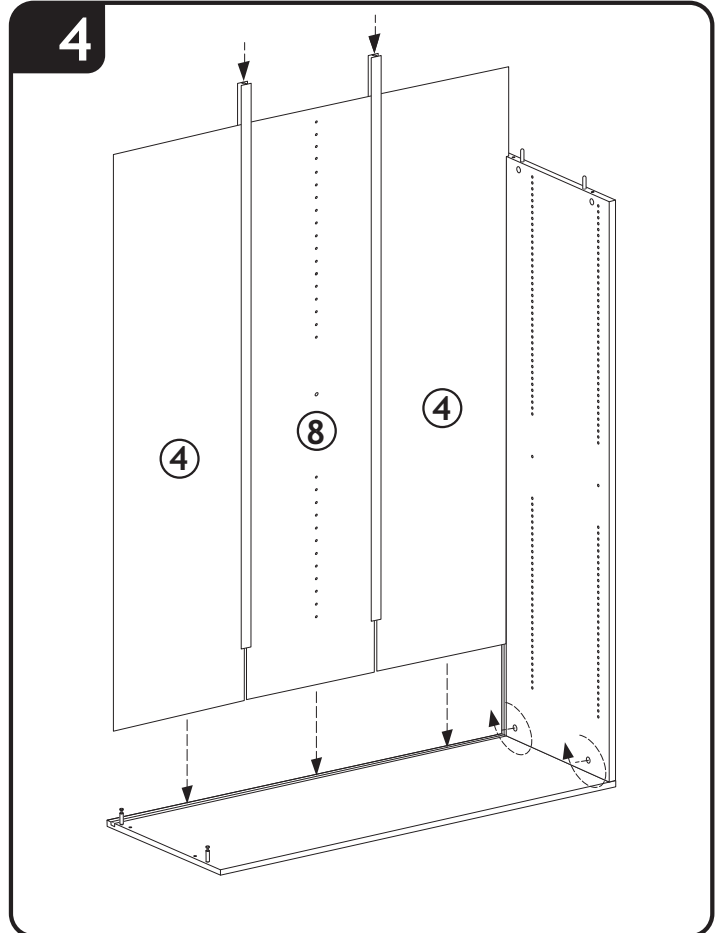
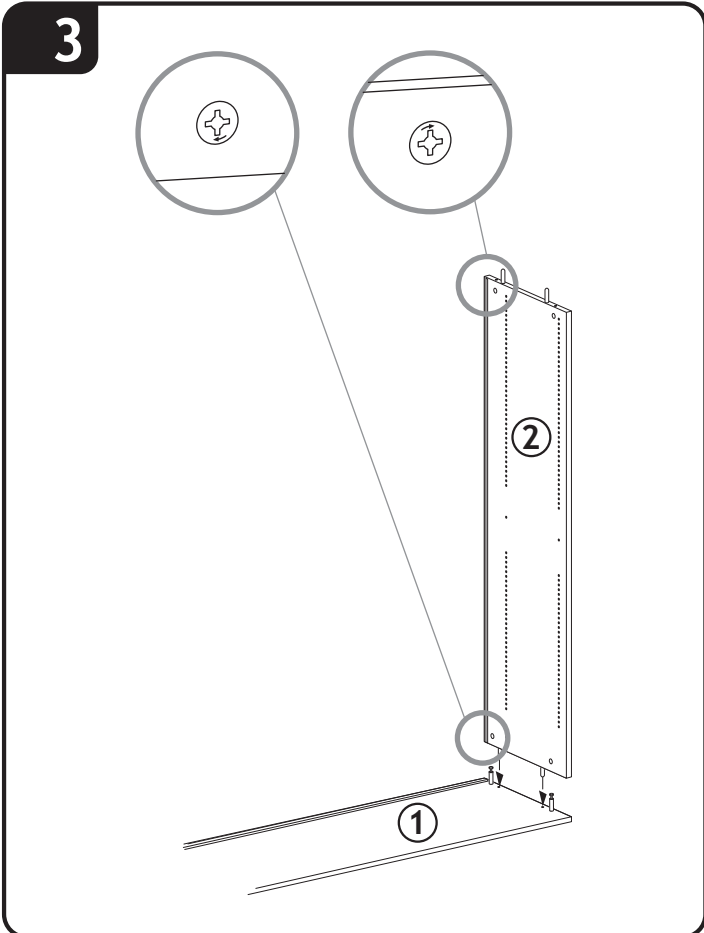
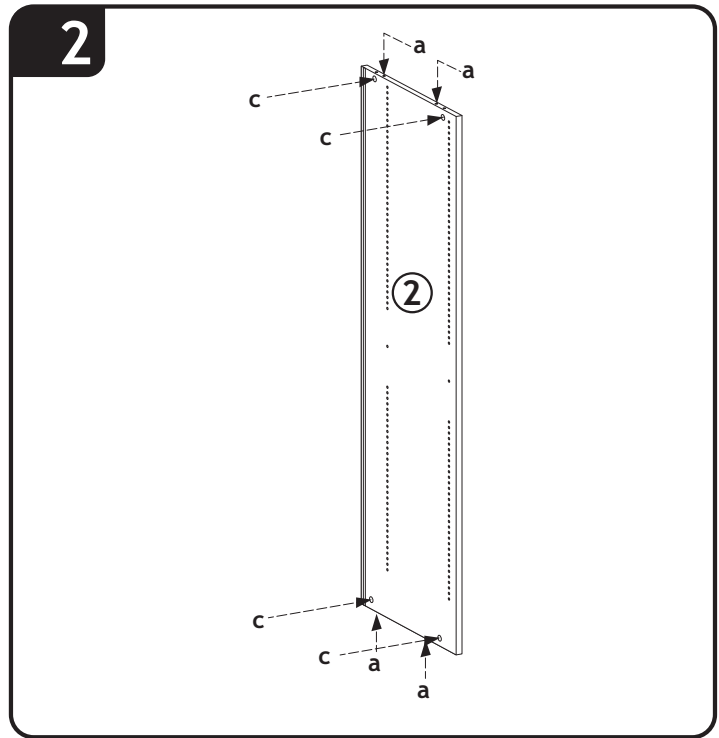
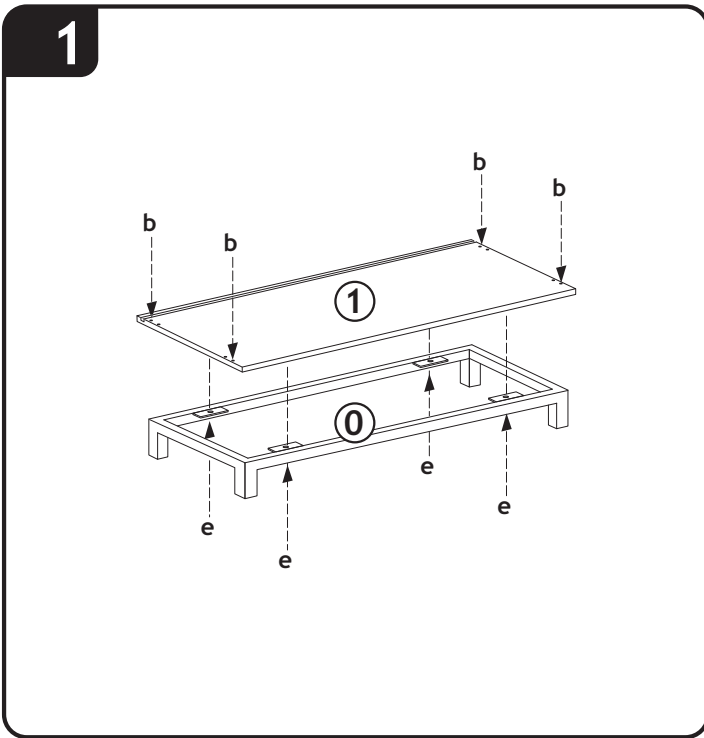
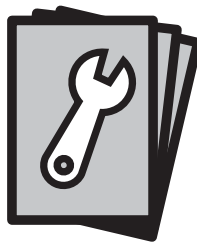

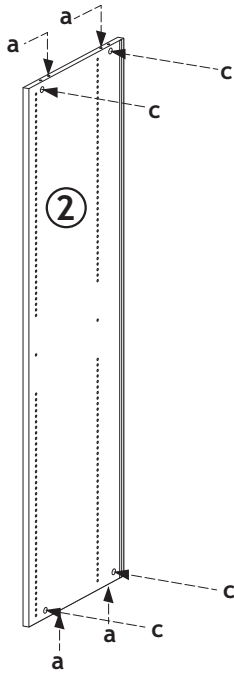
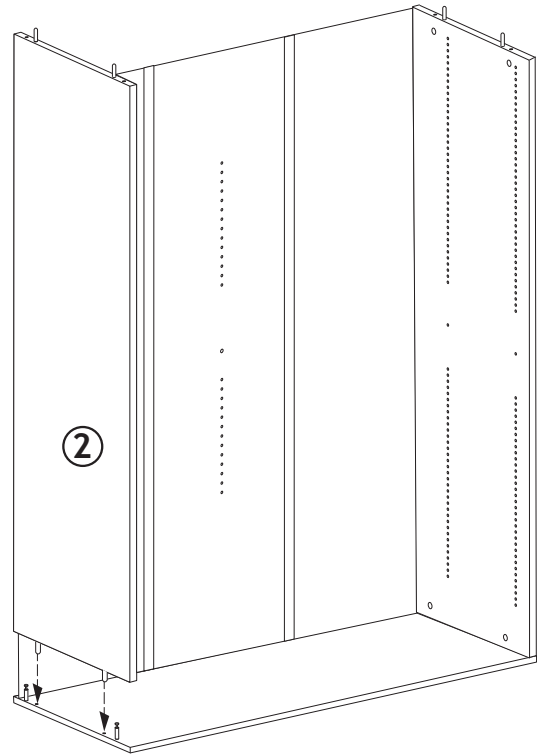
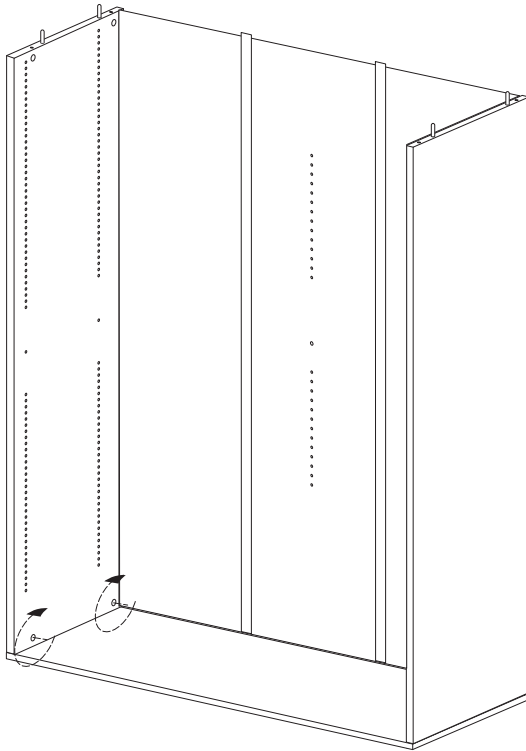
5**6****7**

8

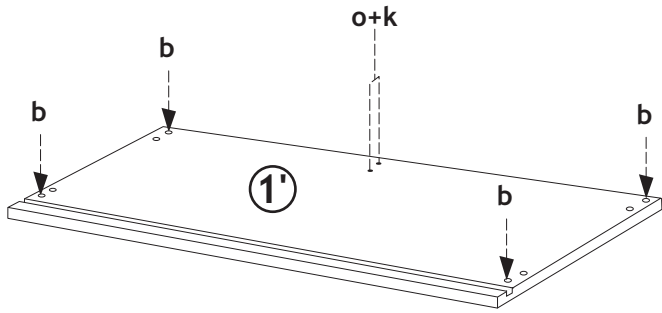

9

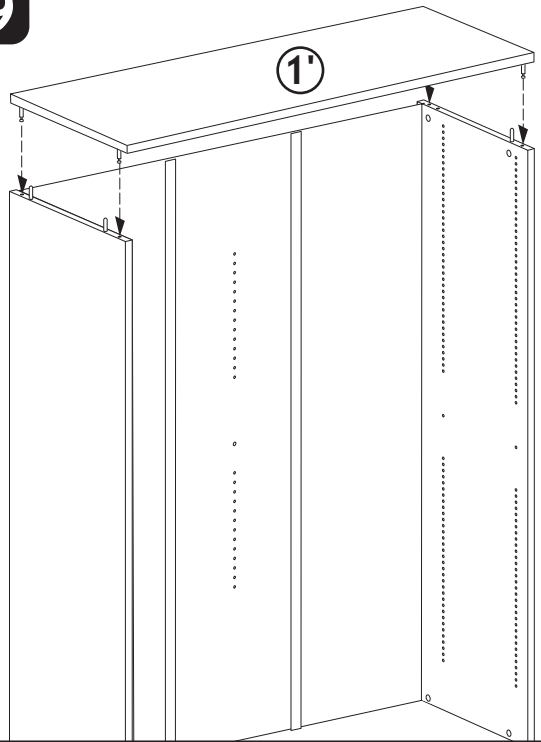

10

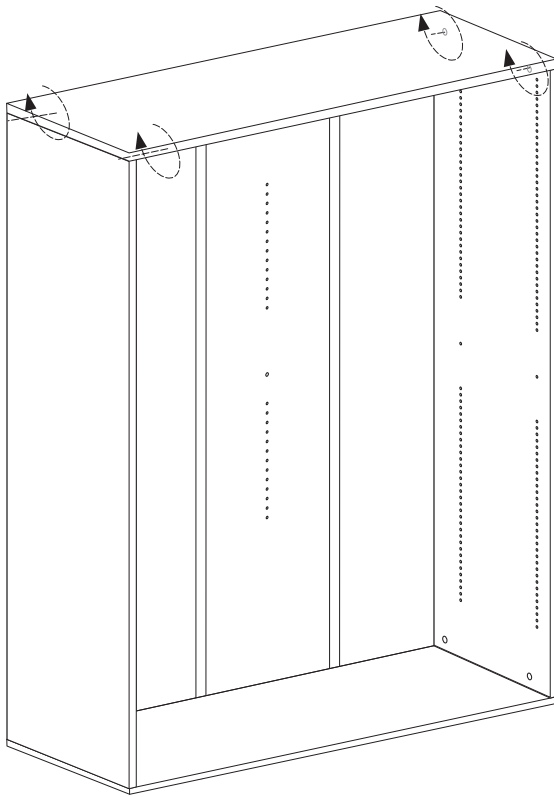

11

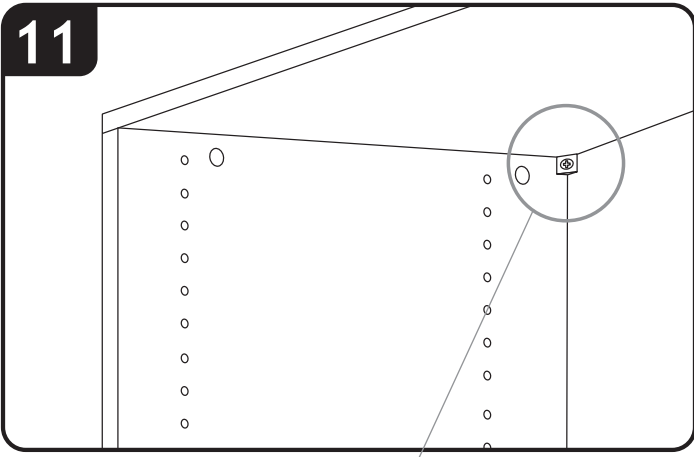

12

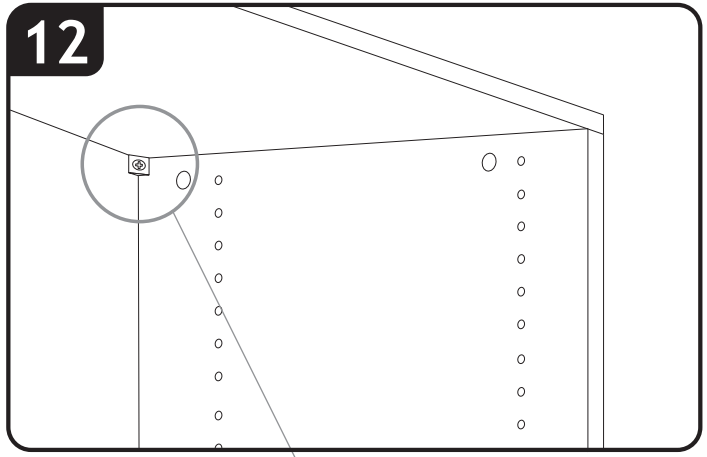

1

2

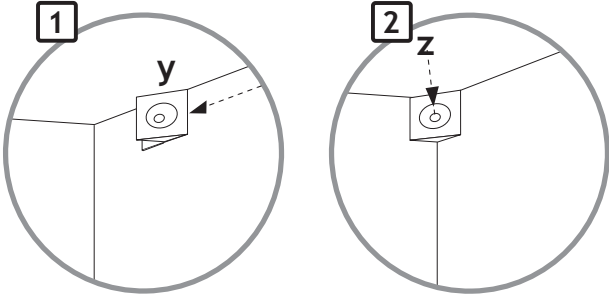

1

2

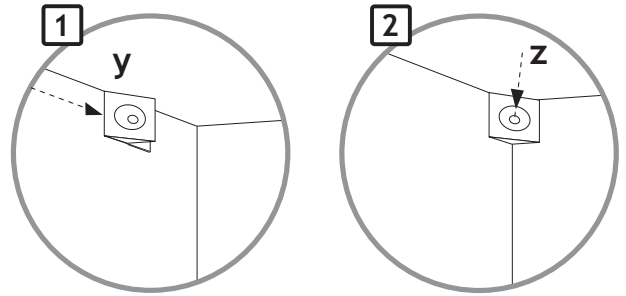

13

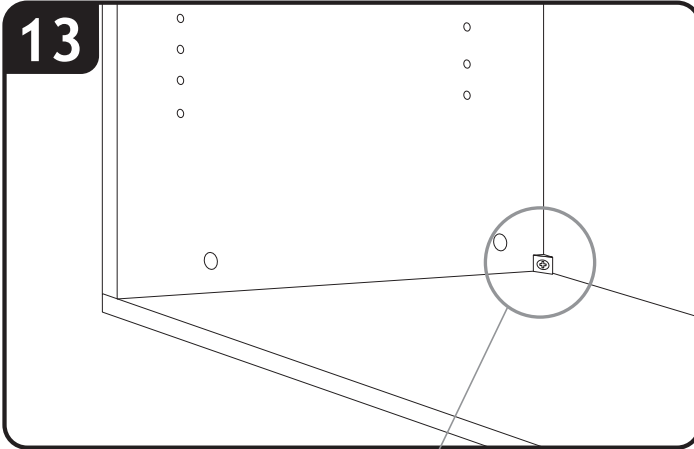

14

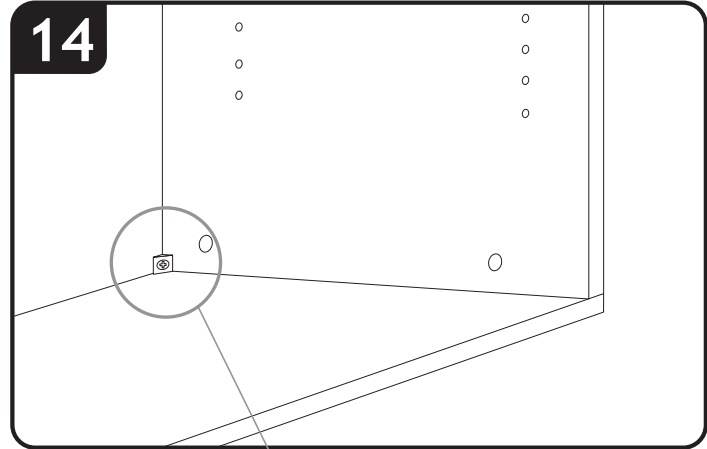

1

2

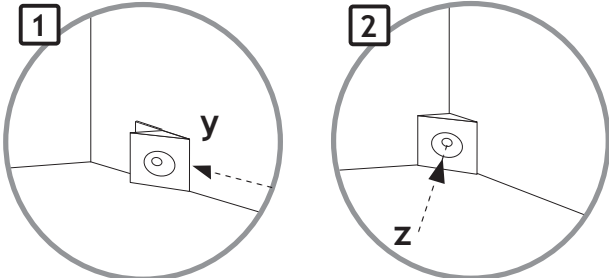

1

2

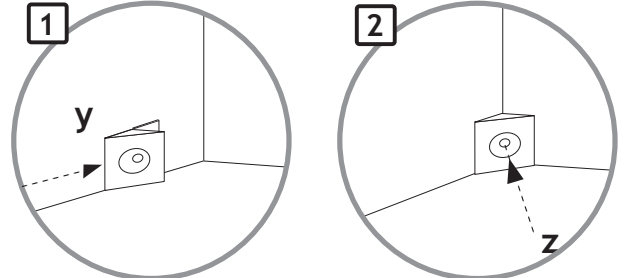

15

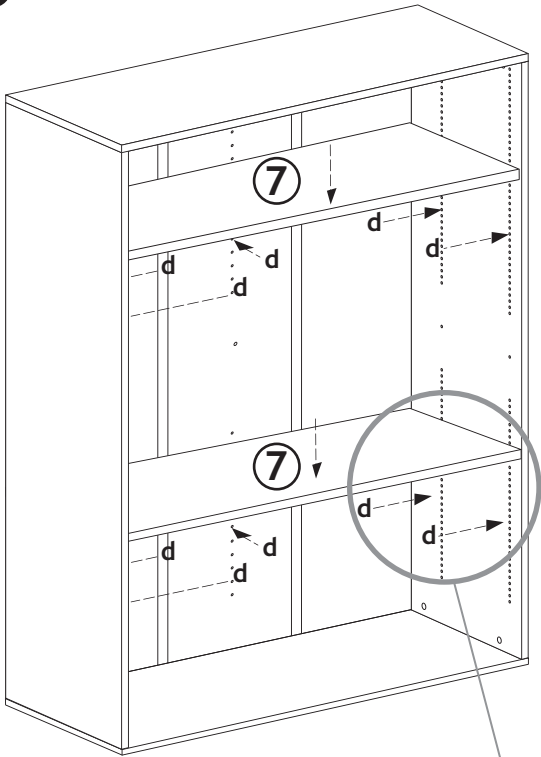

16

35 KG MAX

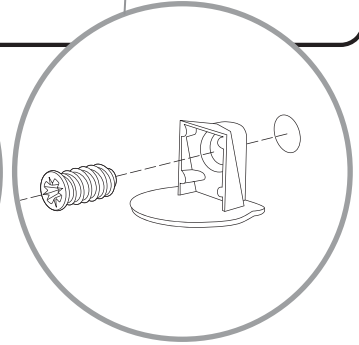
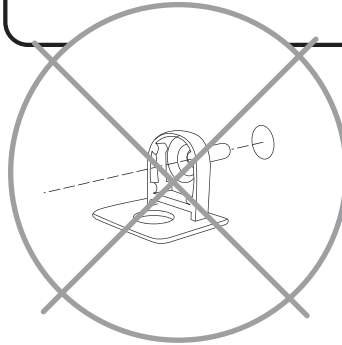
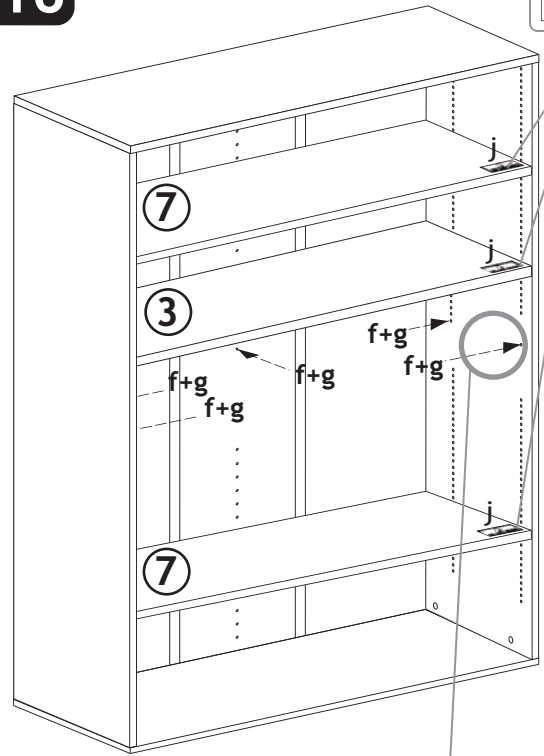

1

2

3

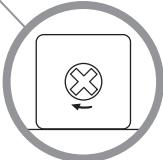
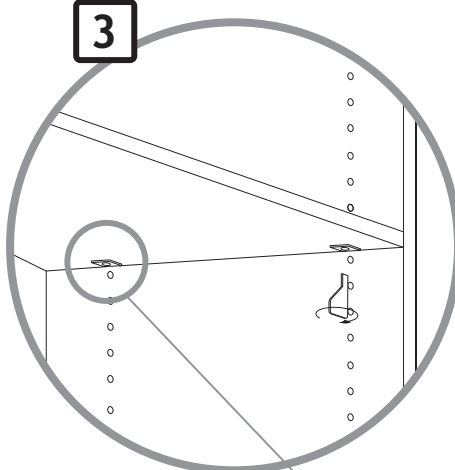
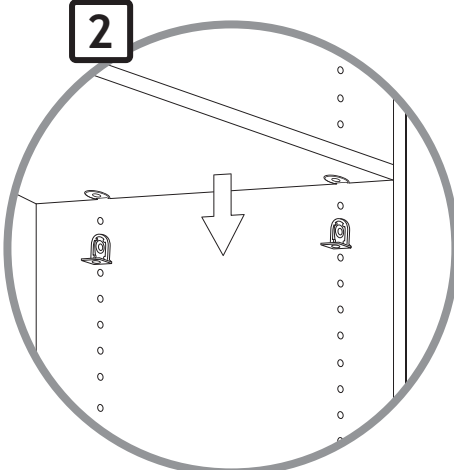
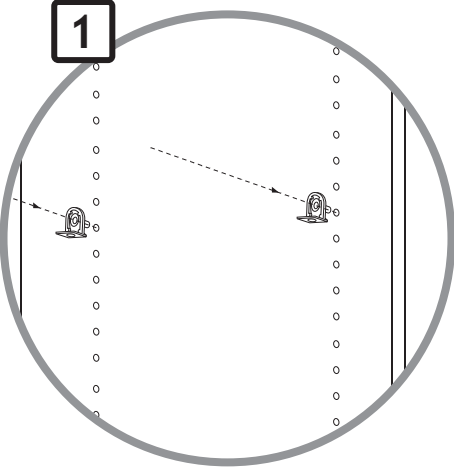

17

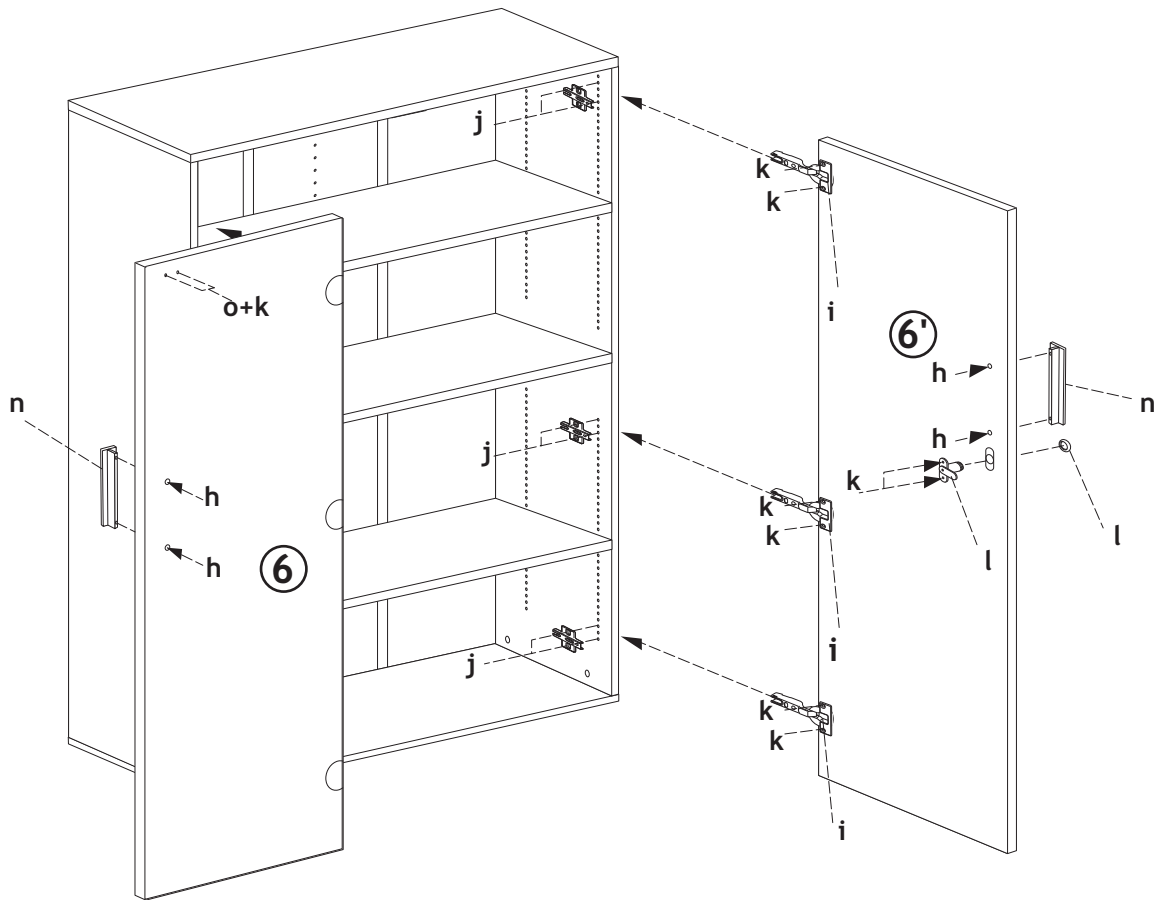

18

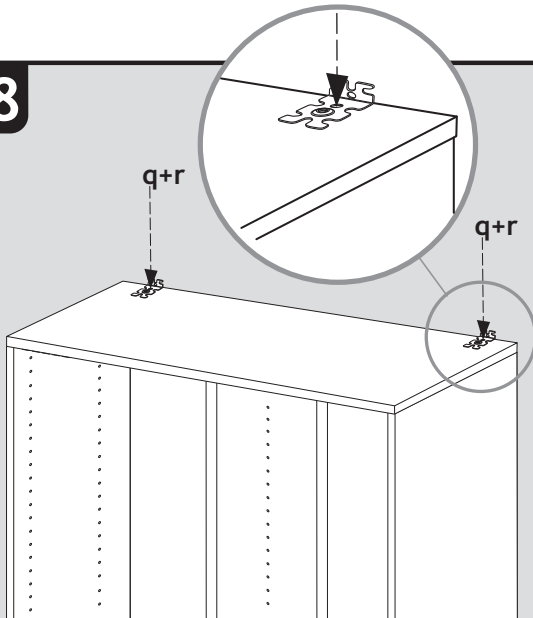

19

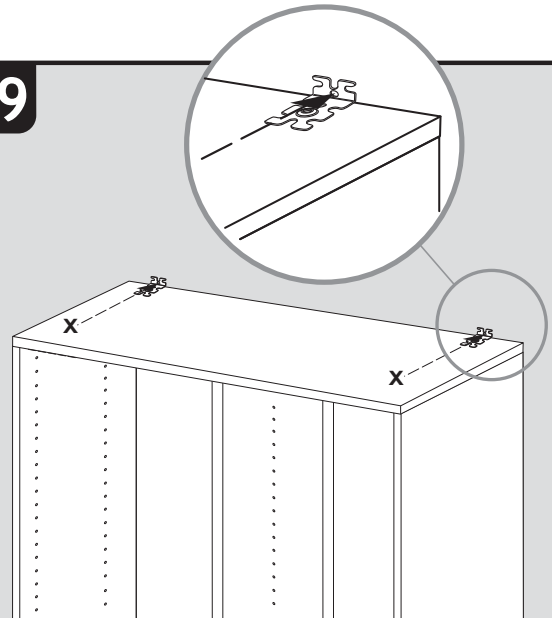

20

