

Zaprojektowany przez	Sprawdzony przez	Zatwierdzony przez	Data		Data	
					2014-02-13	
						
			0530 foundation	Wydanie	Arkusz	
					1 / 1	

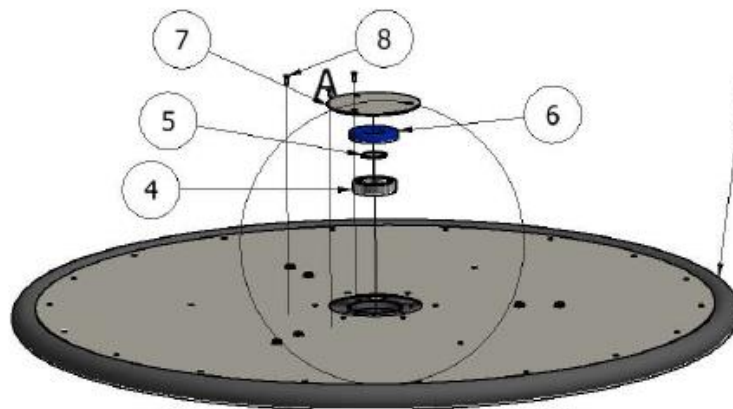

5. Cover the hole with aluminium disc.

4. Push the seal.

3. Push Seiger's ring
(look for a cut on the axis).

2. Push bearing on axis.

1. Put corpse of carousel on the axis
(Bottom bearing and seal is already installed)

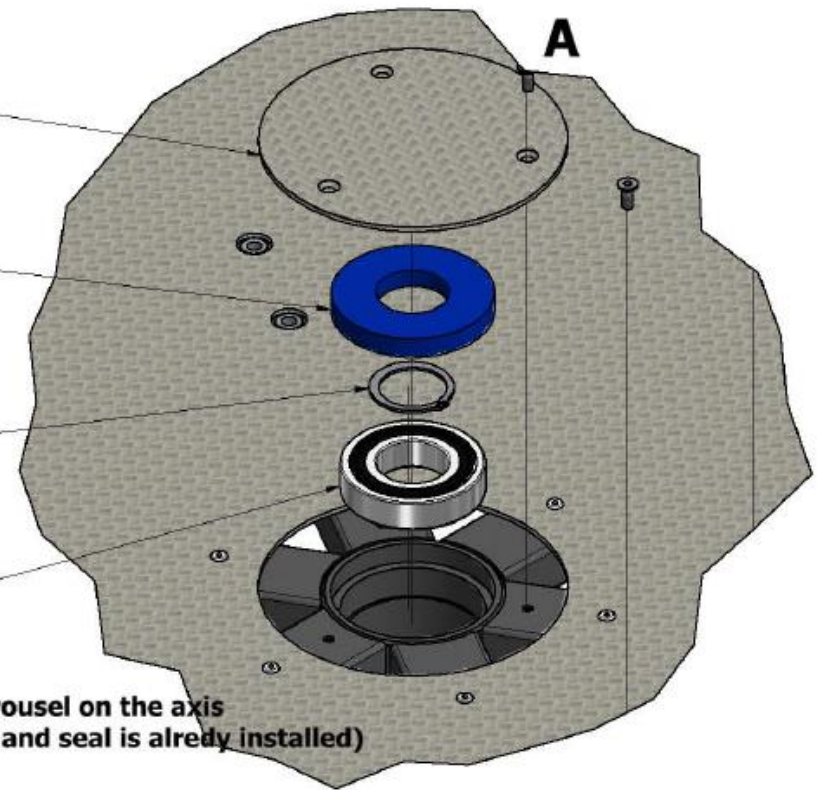

LISTA CZĘŚCI			
ELEMENT	ILOŚĆ	NR CZĘŚCI	OPIS
1	2	50-G53	Axis
2	1	0530 korpus kpl	Corpse
3	2	50-G01	Ribbed bar fi14x200
4	1	6208-2RS1	Bearing
5	1	PN-81/M-85111 - Z 40	Seiger's ring
6	1	U-90x40	Sealing 90x40
7	1	50-K2A30	Disc cover

Zaprojektowany przez	Sprawdzony przez	Zatwierdzony przez	Data	Data
				2010-01-15



Installation guide

0530

Wydanie

Arkusz

1 / 1